



OPTIWAVE-M 7500 Supplementary Instructions

IECEX supplementary instructions



1	General safety information	3
<hr/>		
1.1	Scope of the document	3
1.2	Device description	3
1.3	Standards and approvals.....	3
1.4	Equipment protection levels (EPL).....	4
1.5	Nameplate	4
2	Installation	5
<hr/>		
2.1	Special conditions.....	5
2.2	Precautions.....	5
2.2.1	General notes.....	5
2.2.2	Electrostatic discharge	5
2.2.3	Optional purging system.....	7
2.2.4	Optional pressure transmitter.....	7
2.3	Ambient and process connection temperatures	8
3	Electrical connections	10
<hr/>		
3.1	General notes	10
3.2	Terminal compartment	11
3.2.1	How to open the terminal compartment	11
3.2.2	How to close the terminal compartment	12
3.3	Terminal tightening capacity.....	13
3.4	Equipotential bonding system	13
3.5	How to connect the electrical cables	13
3.6	Maximum intrinsically safe values for the electrical circuit	14
3.7	Supply voltage	14
4	Start-up	15
<hr/>		
5	Service	16
<hr/>		
5.1	Periodic maintenance.....	16
5.2	Repairs.....	16
5.3	Cleaning.....	16
5.4	How to replace the OPTIWAVE-M 7500 level transmitter	16
5.5	Returning the device to the manufacturer.....	17
5.5.1	General information.....	17
5.5.2	Form (for copying) to accompany a returned device.....	18
6	Notes	19
<hr/>		

1.1 Scope of the document

These instructions are applicable only to the explosion-protection version of the radar level transmitter. For all other data, use the Quick Start and Handbook. If you do not have these documents, please contact the nearest office or download them from the manufacturer's website.

**INFORMATION!**

The information in these supplementary instructions only contains the data applicable to explosion protection. The technical data for the non-Ex version in the Handbook shall be valid in its current version, provided that it is not rendered invalid or replaced by these supplementary instructions.

**WARNING!**

Installation, commissioning and maintenance may only be carried out by "Personnel trained in explosion protection".

1.2 Device description

The OPTIWAVE-M 7500 measures level, volume, distance to surface and reflectivity of liquids, pastes and slurries.

Measurements are displayed via a DTM (device type manager) for remote communication or on an optional integrated display screen with wizard-driven setup.

The level transmitter is approved for use in potentially explosive atmospheres when equipped with the appropriate options.

An external transmitter, to measure process pressure, is optional.

1.3 Standards and approvals

**DANGER!**

In compliance with the IECEx scheme rules, the IECEx version of the device described in these Supplementary Instructions agrees with International Standards IEC 60079-0:2017, IEC 60079-11:2011 and IEC 60079-26:2014. The device is certified for use in hazardous areas by CSA Group under certificate of conformity IECEx KIWA 17.0012X. You can download the certificate from our website.

**WARNING!**

Carefully read the IECEx certificate of conformity. Obey the boundary conditions.

1.4 Equipment protection levels (EPL)

The device has the marking that follows:

- Ex ia IIC T6...T3 Ga/Gb

The Ex ia-approved device is suitable for use in potentially explosive atmospheres of all flammable substances in Gas Groups IIA, IIB and IIC. It is certified for applications requiring EPL Ga/Gb.



INFORMATION!

EPL Ga/Gb equipment can be installed in:

- *the boundary wall between zone 0 and zone 1 (the antenna is in zone 0 and the signal converter is in zone 1),*
- *zone 1, or*
- *zone 2*

1.5 Nameplate

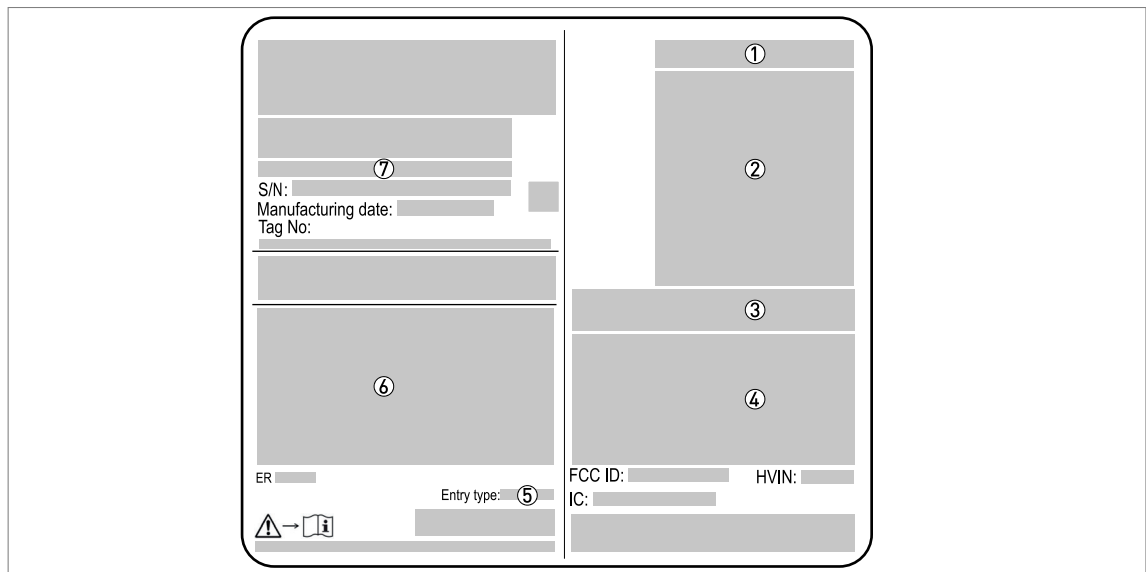

Figure 1-1: Nameplate on the signal converter housing

- ① Certificate number
- ② Types of device protection for explosive gas atmospheres
- ③ Intrinsically safe circuit data. Refer to ⑥ for the input voltage range.
- ④ WARNING: Potential electrostatic charging hazard – see instructions
For more data, refer to *Electrostatic discharge* on page 5.
- ⑤ Cable entry type and size (M20×1.5, M25×1.5)
- ⑥ Input voltage range and maximum current
- ⑦ Type code

2.1 Special conditions

This device can be installed on the applicable auxiliary equipment: a bypass chamber, a stilling well or a communicating pipe.

2.2 Precautions

2.2.1 General notes

**WARNING!**

When you install the device, obey the conditions in the IECEx certificate of conformity. These conditions include:

- *The special conditions for safe use.*

You can download the certificate from our website.

**DANGER!**

This installation must agree with IEC 60079-14: Explosive atmospheres – Part 14: Electrical installations design, selection and erection.

Make sure that:

- you can get access to the device,
- there is sufficient space around the device for inspections,
- you can see the device nameplate, and
- there are no external forces or shocks applied on the device.

2.2.2 Electrostatic discharge

**DANGER!**

Risk of electrostatic discharge (ESD) from the Lens antenna and painted surfaces.

To avoid ignition hazards due to electrostatic charge, devices must not be used in areas where they are exposed to processes that generate strong charges.

Processes that generate strong charges are for example:

- Mechanical friction and cutting processes
- Spraying of electrons (e.g. in the vicinity of electrostatic painting systems)
- Pneumatically conveyed dusts

**WARNING!**

*Electrostatic charging of the housing surface by friction must be avoided.
The device must not be cleaned with a dry cloth.*

ESD warning

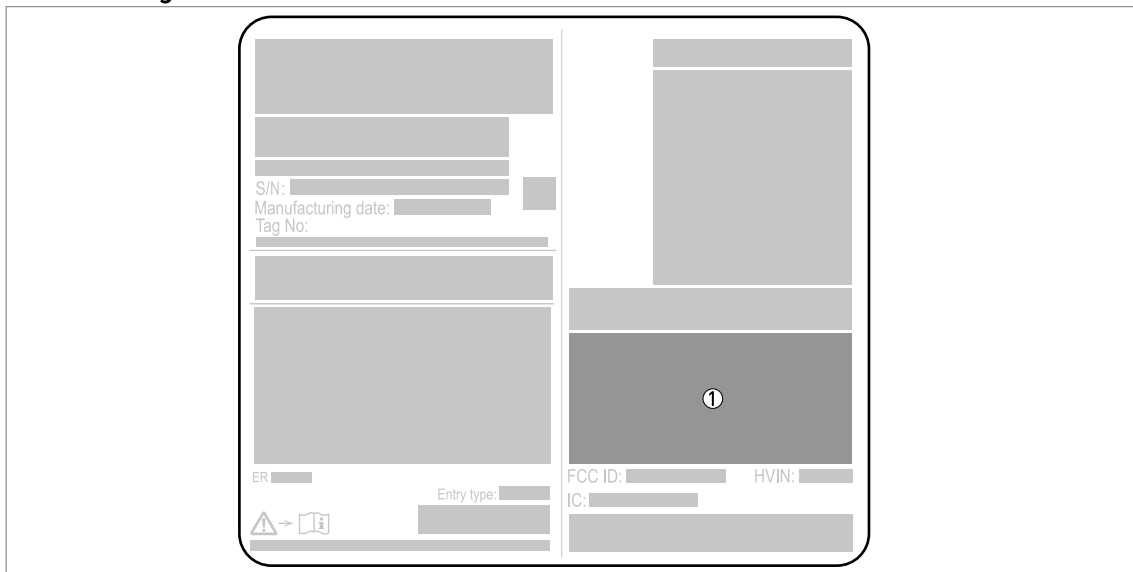

Figure 2-1: ESD warning (on the device nameplate)

- ① Text: Warning! Potential electrostatic hazard – see instructions

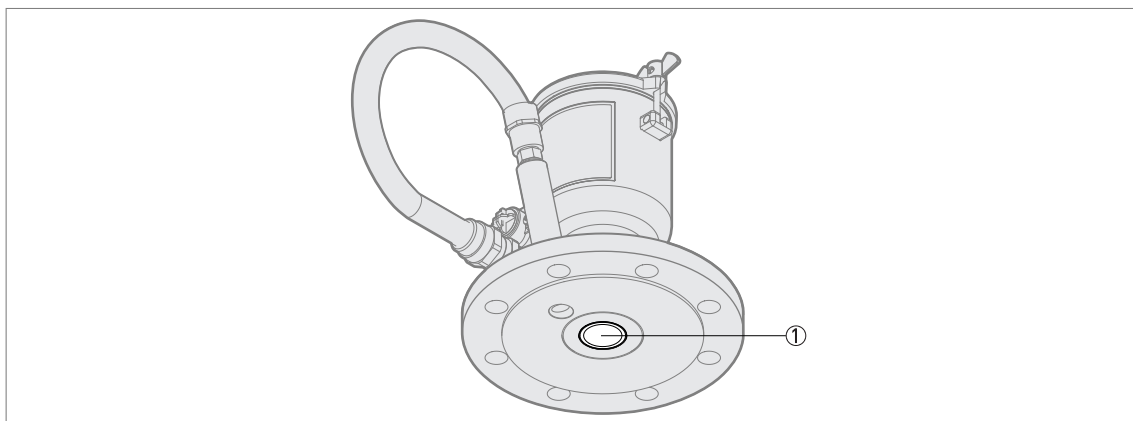

Figure 2-2: Risk of ESD

- ① Lens antenna

2.2.3 Optional purging system

This option is applicable to:

- devices that have a DN40 Lens antenna

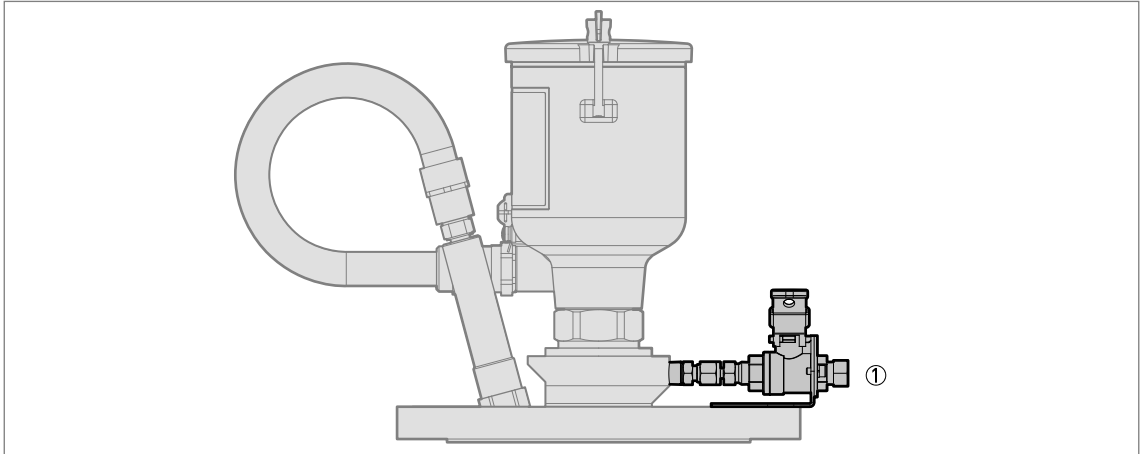

Figure 2-3: Purging system

① NPTF purging connection



INFORMATION!

If delivered with the device, the purging connection is plugged with a 1/4 NPTF screw and engaged on a minimum of 3½ threads.



CAUTION!

If the 1/4 NPTF screw is removed from the purging connection, make sure that the installation agrees with the Ex requirements for the purging system.

Connection and operation of the purging connection are the responsibility of the user. The operator is also responsible for selection of a suitable fluid to purge the device.

Devices installed in an explosive gas atmosphere

- The purging fluid temperature must be less than the ignition temperature of the explosive gas or explosive vapour atmosphere
- The purging fluid temperature must be between the minimum and maximum limits for the gasket (for more data, refer to the handbook) and the type of antenna (for more data refer to *Ambient and process connection temperatures* on page 8)

2.2.4 Optional pressure transmitter

If the device has the pressure transmitter option, it is attached to the flange with a threaded connection.



CAUTION!

If the device does not have the pressure transmitter option, the threaded hole in the flange is sealed with a screw plug. Do not remove this screw plug.

2.3 Ambient and process connection temperatures

The device has more than one applicable temperature class. Refer to the tables that follow to find the applicable temperature limits of your installation.



WARNING!

An explosive atmosphere is a mixture of air and flammable gases, vapour, mist or dust in atmospheric conditions. If you do not use the device in these conditions ($T_{atm} = -20...+60^{\circ}\text{C}$ and $p_{atm} = 0.8...1.1 \text{ barg}$), do an analysis of the risk of ignition.

T_{atm} = atmospheric temperature and p_{atm} = atmospheric pressure.



WARNING!

The gasket temperature must be in the approved limits. For more data, refer to "Pressure and temperature ranges" in the Installation chapter of the handbook. The type of gasket and gasket material must agree with the process.



WARNING!

The reference point for the process temperature is the flange facing of the device. In the tables that follow, this reference point will be referred to as the "process connection temperature".



WARNING!

Make sure that the maximum process connection temperature and maximum ambient temperature are not more than the values given in the tables.

The tables that follow are applicable in these conditions:

- Device installation must agree with the instructions given in the handbook.
- Make sure that the device temperature does not increase because of other heat sources (sunlight, adjacent system components etc.). The device must not be operated above the maximum permitted ambient temperature.
- Do not put insulation around the signal converter. Make sure that the airflow around the signal converter is sufficient. It is permitted to have insulation on the pipe or stilling well and the process connection.

Temperature class for EPL Ga/Gb, EPL Gb or EPL Gc	Maximum ambient temperature	Maximum process connection temperature (max. process temperature)
	[°C]	
T6	+60	+60
	+43	+85
T5	+75	+75
	+58	+100
T4	+56	+115
	+53	+120

Temperature class for EPL Ga/Gb, EPL Gb or EPL Gc	Minimum ambient temperature	Minimum process connection temperature (min. process temperature)
	[°C]	
All classes ①	-40	-40

① Min. process connection temperature is -20°C, if a Kalrez® gasket is used

3.1 General notes



WARNING!

De-energize the circuit before you connect or disconnect the device.

- *De-energize the circuit.*
- *Use the applicable cable glands for the cable entry openings in the housing (M20×1.5 or M25×1.5). For the cable entry size, refer to the device nameplate.*

3.2 Terminal compartment

3.2.1 How to open the terminal compartment



WARNING!

- Do not blow dust with compressed air if it collects on the housing. Clean the device with a damp cloth before you remove the terminal compartment cover.
- Make sure that no dust goes into the electrical compartment after you open the cover.

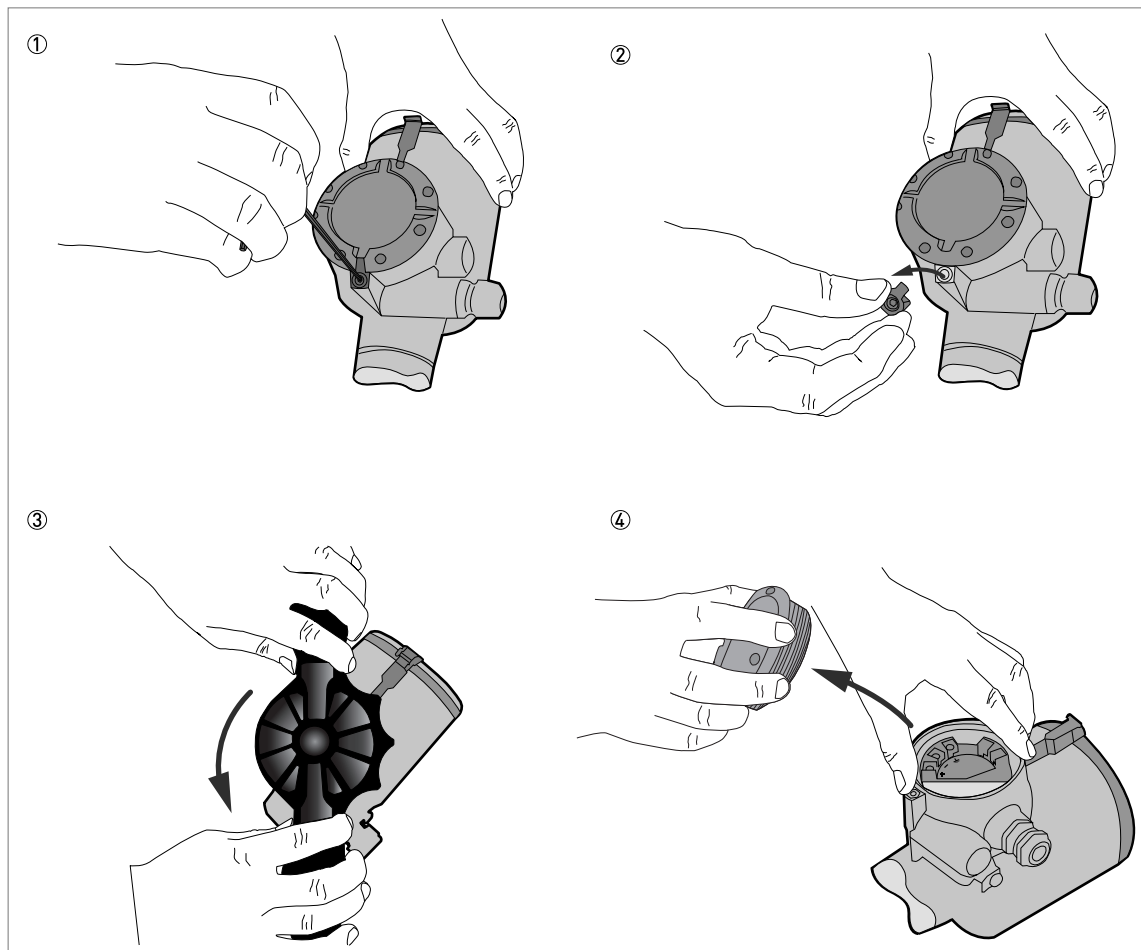

Figure 3-1: How to open the terminal compartment cover

Equipment needed

- Wrench (supplied)
- 3-mm Allen wrench (not supplied)



- Use the 3-mm Allen wrench to remove the cover stop.
- Use the wrench to remove the cover.

For more data about the procedure, refer to the handbook.

3.2.2 How to close the terminal compartment

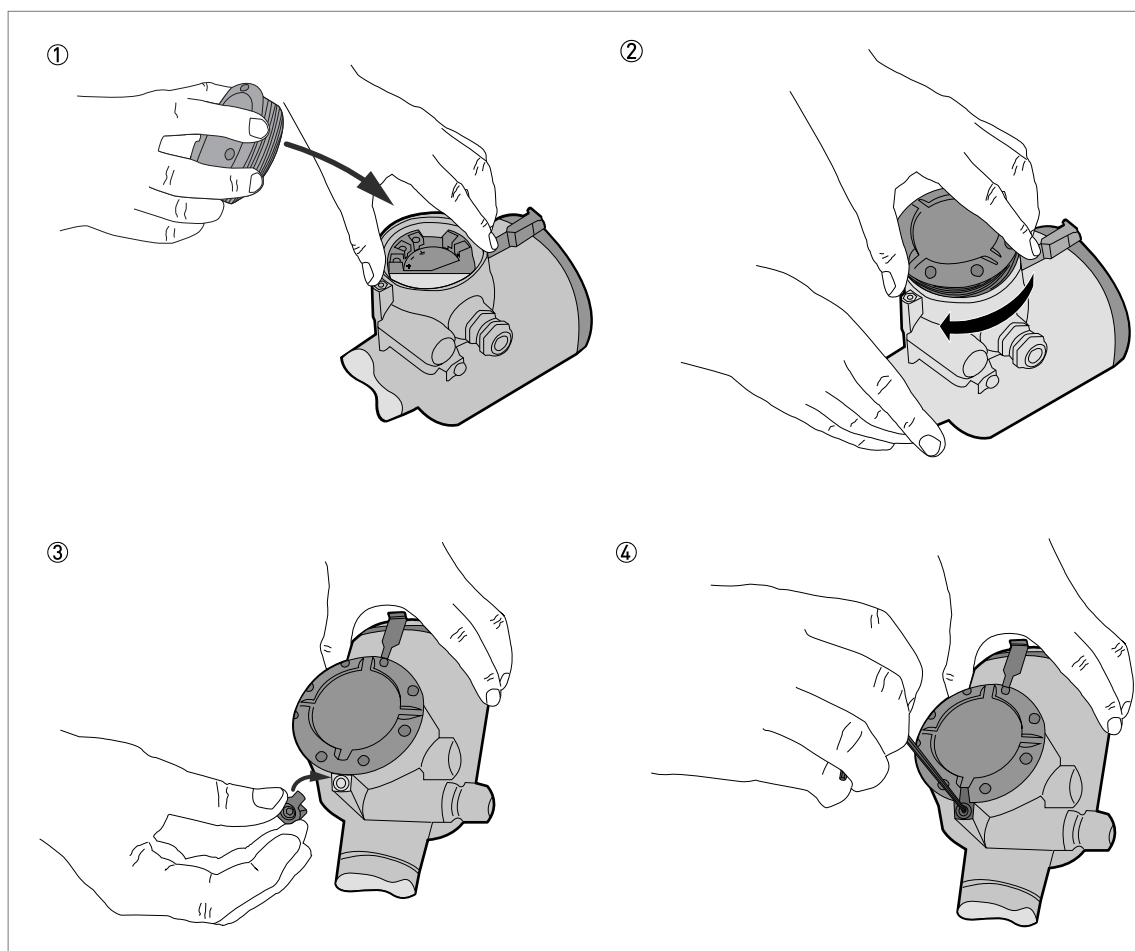

Figure 3-2: How to close the terminal compartment cover

Equipment needed

- Wrench (supplied)
- 3-mm Allen wrench (not supplied)



- Attach the cover. Make sure that a slot on the top of the cover is correctly aligned with the hole for the cover stop.
- Attach the cover stop (make sure that there is also a spring washer and a socket head screw). Tighten the screw with a 3-mm Allen wrench.

3.3 Terminal tightening capacity

The terminal tightening capacity of current output terminals is:

Type of wire	Terminal tightening capacity	
	[mm ²]	[AWG]
Flexible or rigid	2.5	13

3.4 Equipotential bonding system

Connect the device to the equipotential bonding system for the hazardous location.

You can use 2 terminals to connect the device to the equipotential bonding system:

- a ground connection in the terminal compartment and
- an external ground terminal adjacent to the cable entries

You can also use the process connection to connect the device to the equipotential bonding system. Make sure that there is a good electrical connection to the process connection (flange, thread etc.).

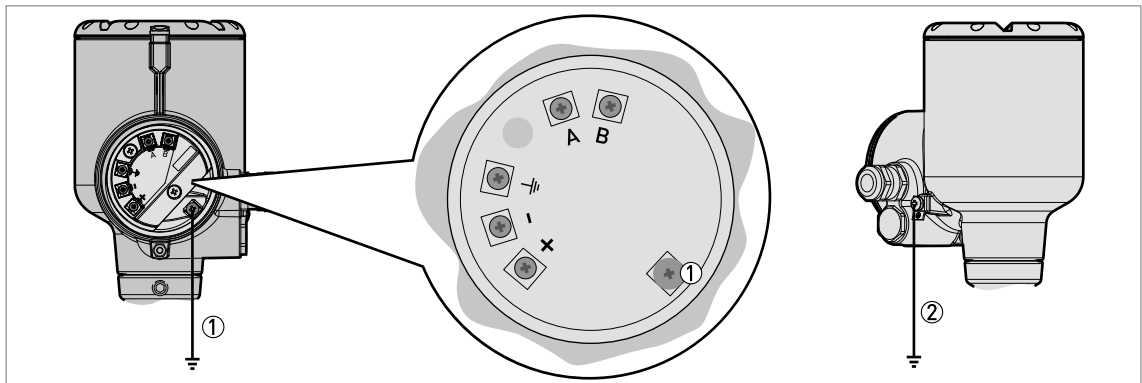

Figure 3-3: Examples of terminals for the equipotential bonding system

- ① Internal terminal
- ② External terminal (on the housing)

The device electronics are isolated with a rating of 500 V_{RMS}.

3.5 How to connect the electrical cables

Refer to the handbook for data about the device terminals.

Cable glands are supplied on customer demand. We recommend that you use a part that has a degree of ingress protection IP ≥ 68. Make sure that the cable gland is sealed.



Obey the instructions that follow:

- Electrical wires must agree with applicable standards (e.g. IEC 60079-14).
- Use the electrical connection procedure in the handbook.

- Put the electrical wires in position and safely attach them to prevent damage. The electrical wires must also be a sufficient distance from hot surfaces.
- Make sure that unused electrical wires are safely connected to the ground potential of the hazardous area. If this is not possible, make sure that each of the unused electrical wires are safely isolated (other electrical wires, ground etc.) and rated for a test voltage $\geq 500 V_{RMS}$.
- If it is necessary, make sure the electrical wire insulation gives good protection from corrosion.
- Connect only to separate certified, intrinsically safe circuits. Make sure that the electrical circuit characteristics are not more than the values that follow.
- Do not remove more than 6 mm / 0.2" of insulation from the wire.
- The minimum thickness of the insulation must be 0.5 mm.



CAUTION!

Power supply:

Connect the electrical wires for the level transmitter to terminal "+" and "-". If your device has the optional pressure transmitter, connect electrical wires from the pressure transmitter to terminal "A" and "B".

3.6 Maximum intrinsically safe values for the electrical circuit

Level transmitter

Output	Intrinsically safe values for the electrical circuit				
	U_i	I_i	P_i	C_i	L_i
	[V]	[mA]	[W]	[nF]	[μ H]
4...20 mA passive – HART	≤ 30	≤ 130	≤ 1	= 10	~ 0



WARNING!

Connect an intrinsically safe barrier to the level transmitter. If your device has the optional pressure transmitter, use a different intrinsically safe barrier for the pressure transmitter. These two intrinsically safe circuits must be galvanically isolated. Make sure that the electrical wires are rated for a test voltage of 500 V_{RMS} .

Pressure transmitter (optional)

For the maximum intrinsically safe values, refer to the nameplate on the pressure transmitter.

3.7 Supply voltage

Level transmitter

Terminals	Minimum DC voltage at output terminals	Maximum DC voltage at output terminals
	[V]	
Terminals + / -	12	30

Pressure transmitter (optional)

For the power supply data, refer to the nameplate on the pressure transmitter.

**WARNING!**

Make sure that it is safe to supply electrical power. Do a start-up check:



- Are the wetted components (gasket, flange and antenna) resistant to corrosion by the tank product?
- Does the information given on the nameplate agree with the application?
- Did you connect the equipotential bonding system correctly?
- Are you using intrinsically safe barriers within the correct parameters? For more data, refer to *Maximum intrinsically safe values for the electrical circuit* on page 14. The electrical circuit characteristics must not be more than the maximum intrinsically safe values.
- Did you install the correct cable glands? Is the terminal compartment correctly sealed?
- Does the purging system agree with Ex requirements?

5.1 Periodic maintenance

In normal operational conditions, no maintenance is necessary. If it is necessary, maintenance must be done by approved personnel (the manufacturer or personnel approved by the manufacturer).

We recommend that you do a regular inspection of the device to make sure that:

- there is no damage or corrosion,
- the process connection is tight,
- the electrical cable is not worn, and
- the power supply terminals are tight.



INFORMATION!

For maintenance and inspection of electrical installations, refer to IEC 60079-17.

5.2 Repairs

Only the manufacturer can repair the device and replace components.

5.3 Cleaning



WARNING!

If you use a cleaning agent, make sure that it is compatible with the wetted-part materials. For more data about these materials, refer to the handbook (technical data).

Obey these instructions:

- Keep the device clean to prevent dust contamination.
- Do not blow dust with compressed air.
- Clean the device with a damp cloth.

5.4 How to replace the OPTIWAVE-M 7500 level transmitter

If you must change the level transmitter, refer to the procedure that follows.



DANGER!

Installation on a tank

Make sure that the tank is not pressurized before you remove the device from the process connection. A pressurized tank can cause injury to persons.



INFORMATION!

Electrical connection

Follow the instructions in the related sections of the handbook and this document (IECEx supplementary instructions).

**INFORMATION!****Start-up**

Follow the instructions in the related sections of the handbook and this document (IECEX supplementary instructions).

**Removing the device**

- ① De-energize the electrical circuits for the device and the optional pressure transmitter (if applicable).
- ② Loosen the terminal compartment cover lock screw with a 3-mm Allen wrench. Remove the terminal compartment cover and loosen the cable glands.
- ③ Disconnect the electrical wires with a POZIDRIV® PZ1 screwdriver. Remove the electrical cables from the terminal compartment.
- ④ Disconnect the equipotential bonding connections with a POZIDRIV® PZ1 screwdriver.
- ⑤ **Tanks/Silos:** If the tank is pressurized, then decrease the pressure to atmospheric pressure.
- ⑥ Remove the device from the process connection.

**Attaching the new device**

- ① Attach the new device to the process connection.
- ② Remove the terminal compartment cover and loosen the cable glands.
- ③ Connect the equipotential bonding connections with a POZIDRIV® PZ1 screwdriver.
- ④ Put the electrical cables in the terminal compartment. Connect the electrical wires with a POZIDRIV® PZ1 screwdriver.
- ⑤ Attach the terminal compartment cover and tighten the terminal compartment cover lock screw with a 3-mm Allen wrench. Tighten the cable glands.
- ⑥ Energize the device and the optional pressure transmitter (if applicable).

5.5 Returning the device to the manufacturer

5.5.1 General information

This device has been carefully manufactured and tested. If installed and operated in accordance with these operating instructions, it will rarely present any problems.

**WARNING!**

Should you nevertheless need to return a device for inspection or repair, please pay strict attention to the following points:

- Due to statutory regulations on environmental protection and safeguarding the health and safety of the personnel, the manufacturer may only handle, test and repair returned devices that have been in contact with products without risk to personnel and environment.
- This means that the manufacturer can only service this device if it is accompanied by the following certificate (see next section) confirming that the device is safe to handle.

**WARNING!**

If the device has been operated with toxic, caustic, radioactive, flammable or water-endangering products, you are kindly requested:

- to check and ensure, if necessary by rinsing or neutralising, that all cavities are free from such dangerous substances,
- to enclose a certificate with the device confirming that it is safe to handle and stating the product used.

5.5.2 Form (for copying) to accompany a returned device



CAUTION!

To avoid any risk for our service personnel, this form has to be accessible from outside of the packaging with the returned device.

Company:		Address:	
Department:		Name:	
Telephone number:		Email address:	
Fax number:			
Manufacturer order number or serial number:			
The device has been operated with the following medium:			
This medium is:	radioactive		
	water-hazardous		
	toxic		
	caustic		
	flammable		
	We checked that all cavities in the device are free from such substances.		
	We have flushed out and neutralized all cavities in the device.		
We hereby confirm that there is no risk to persons or the environment caused by any residual media contained in this device when it is returned.			
Date:		Signature:	
Stamp:			

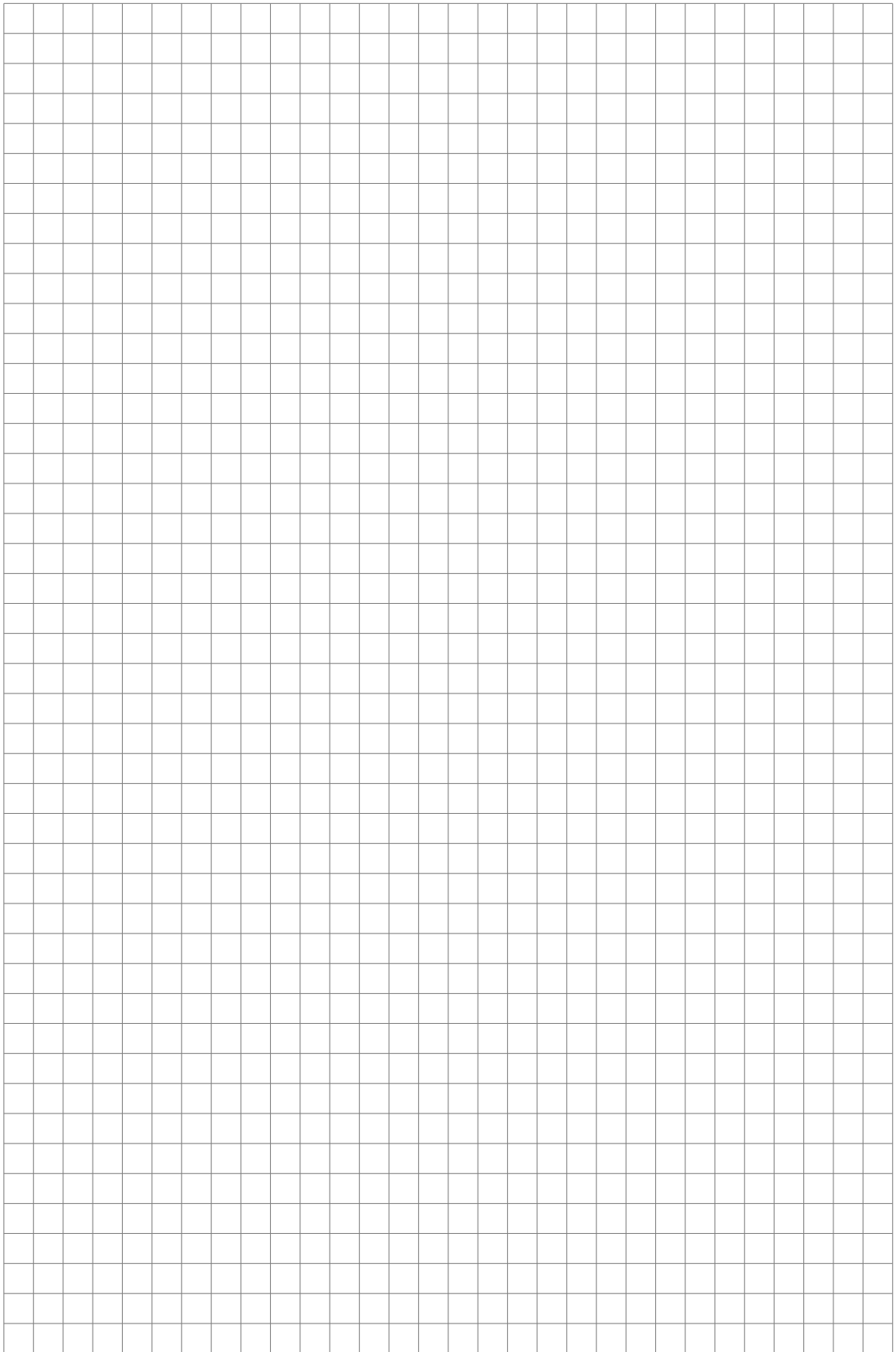

KROHNE – Products, Solutions and Services

- Process instrumentation for flow, level, temperature, pressure measurement and process analytics
- Flow metering, monitoring, wireless and remote metering solutions
- Engineering, commissioning, calibration, maintenance and training services

Head Office KROHNE Messtechnik GmbH
Ludwig-Krohne-Str. 5
47058 Duisburg (Germany)
Tel.: +49 203 301 0
Fax: +49 203 301 10389
info@krohne.de

The current list of all KROHNE contacts and addresses can be found at:
www.krohne.com

KROHNE